

Precision Welding Lathes

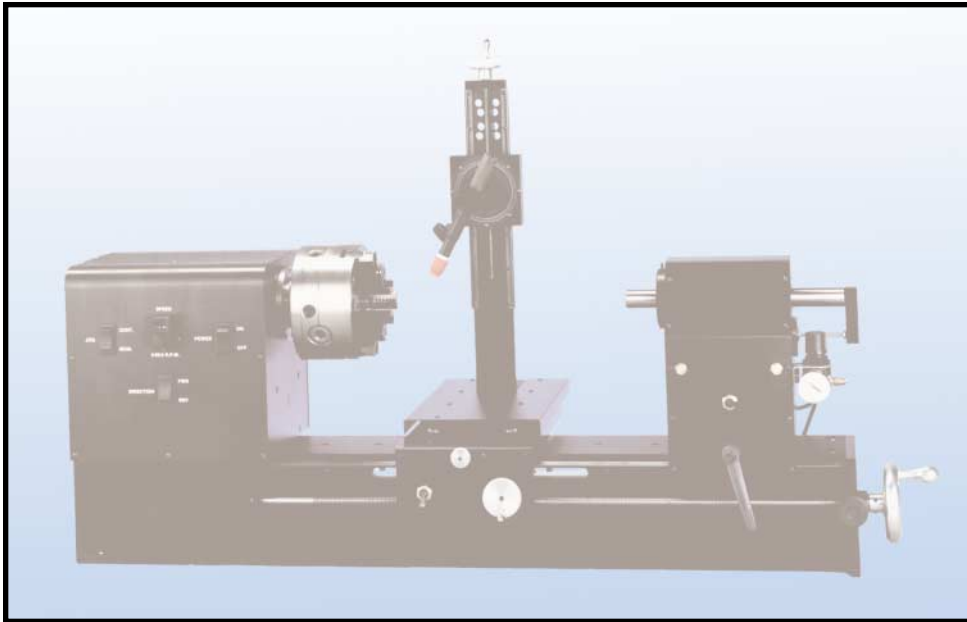

Improve Weld Quality

Increase Weld Output

Lower Labor Costs

The Pro-Fusion Precision Welding Lathe is designed to allow unskilled personnel to consistently produce high quality welds on a wide range of circumferential parts. With over 15 years of welding experience, Pro-Fusion can assist in weld schedule development and tooling in order to provide a complete, turn-key automatic welding system.

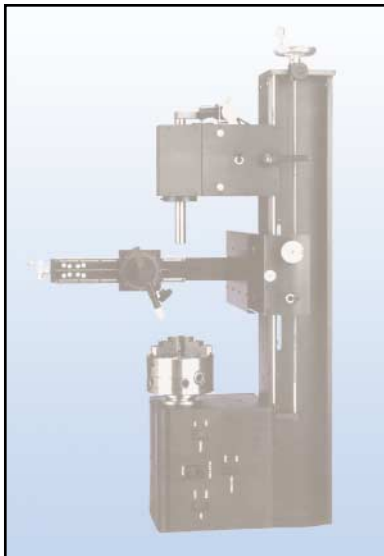

- Rigid, machined frame construction provides a solid, non-flexing platform for Headstock, Tailstock, and Torch Tower
- Air actuated torch stand with variable speed controls
- Air actuated Tailstock with pressure and speed controls
- Lathe Tilts 90° for vertical welding position
- Custom designed welding speed control ensures extreme accuracy for precision part motion
- Longer lathe beds available up to 72"

Pro-Fusion Technologies, Inc.

10901 McBride Lane, Knoxville TN, 37932.

Phone: 865.671.7682. Fax: 865.671.7686.

Web site: www.Pro-FusionOnline.com

Pro-Fusion Lathes As Part of Complete Automated Welding Systems

A complete Pro-Fusion welding system offers computer control of critical welding parameters including programmable peak and background welding current, arc pulsation, upslope, downslope, pre and post purge gas control. Pro-Fusion TIG/Micro-TIG and Plasma/Micro-Plasma welding power sources are available as a completely integrated package with a Pro-Fusion lathe. An optional touch-retract system allows for precise tungsten to work gap settings for additional torch positioning.

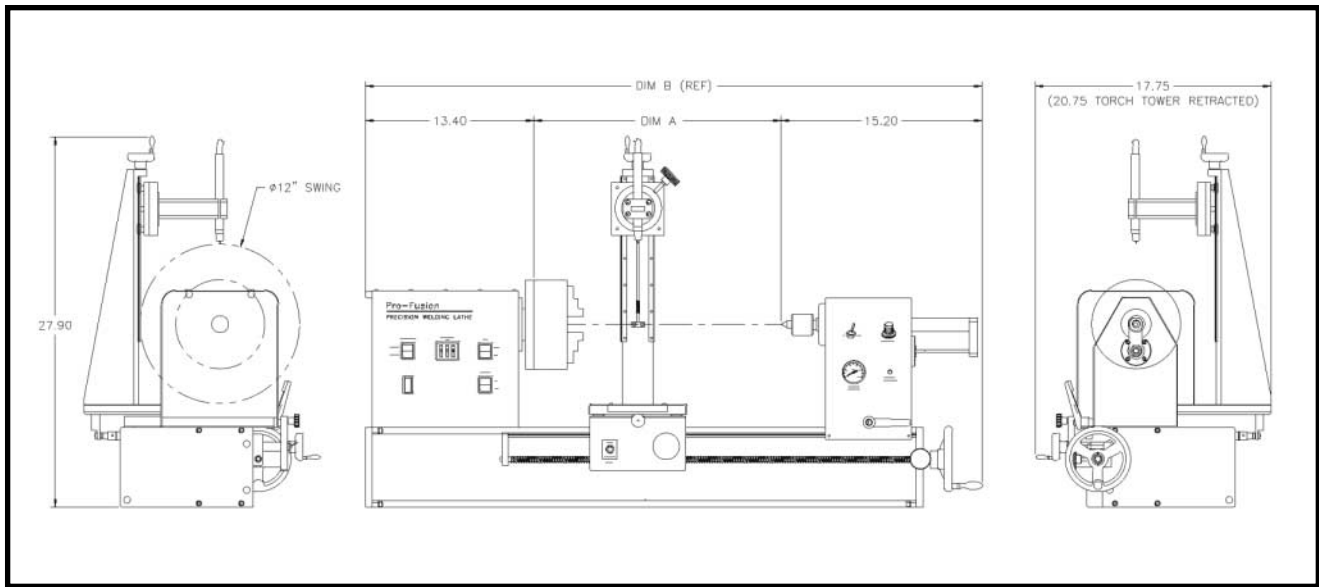

Specifications

- Maximum 12" swing
- T.I.R. .0005
- Tailstock stroke - 4"
- Tailstock Force - 50 lbs.
- Distance between centers - 18" to 72"
- 1½" Headstock through hole

Lathe Size Tabulation

<u>Part #</u>	<u>DIM A</u>	<u>DIM B</u>
PFL-12-18	18"	46.6"
PFL-12-24	24"	52.6"
PFL-12-30	30"	58.6"
PFL-12-36	36"	64.6"
PFL-12-42	42"	70.6"
PFL-12-72	72"	103.6"

Other Products Available from Pro-Fusion:

- TIG/Micro-TIG power supplies
- Plasma/Micro-Plasma power supplies
- Gap setting devices
- Tungsten Electrode Grinders
- Pre-Ground Welding Electrodes
- Arc Distance Contollers
- Plasma Welding Torches and Spare Parts
- Reverse Polarity Cleaning Equipment

Free Welding Consultations. Call Pro-Fusion at (865) 671-7682.