

Model G450AT Tube to Tubesheet Weldhead

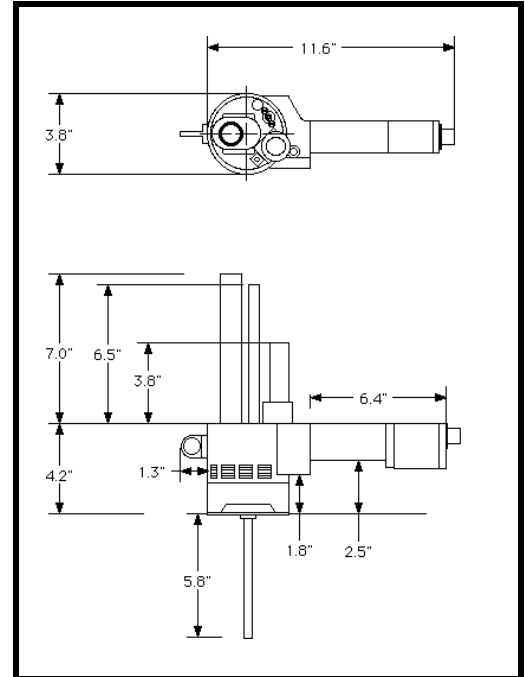

Technical Specifications

Torch Characteristics:	Gas or water cooled 100 amps @ 100% duty cycle 3/32" diameter tungsten standard 1/8" and 1/16" diameter tungsten optional
Physical Dimensions:	Refer to diagrams
Weight:	5½ lbs. (2½ kg) without cables
Tube Sizes:	With 3/8" locator and customer-furnished mandrel: 3/8" to 1½" ID 1/2" to 1¾" OD
Maximum Extended Joint:	1/16" H
Clearance Requirements:	Refer to diagrams

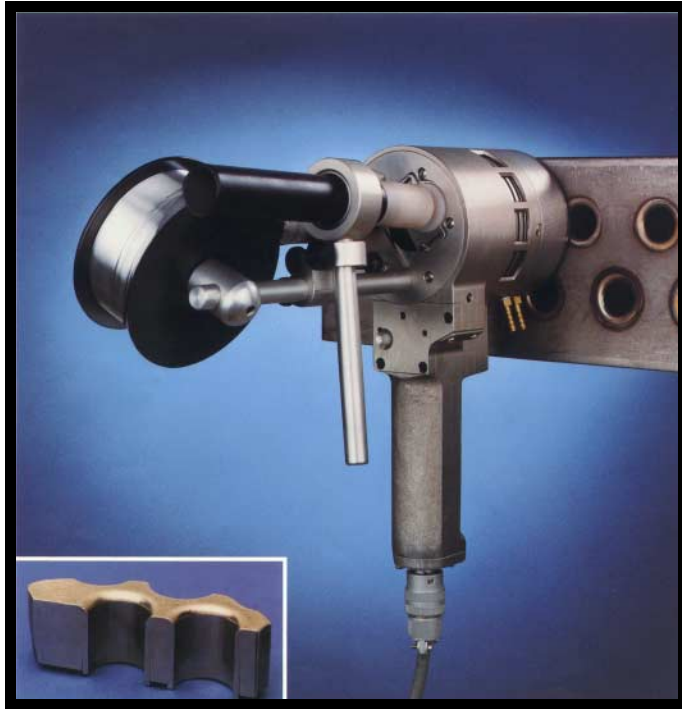